

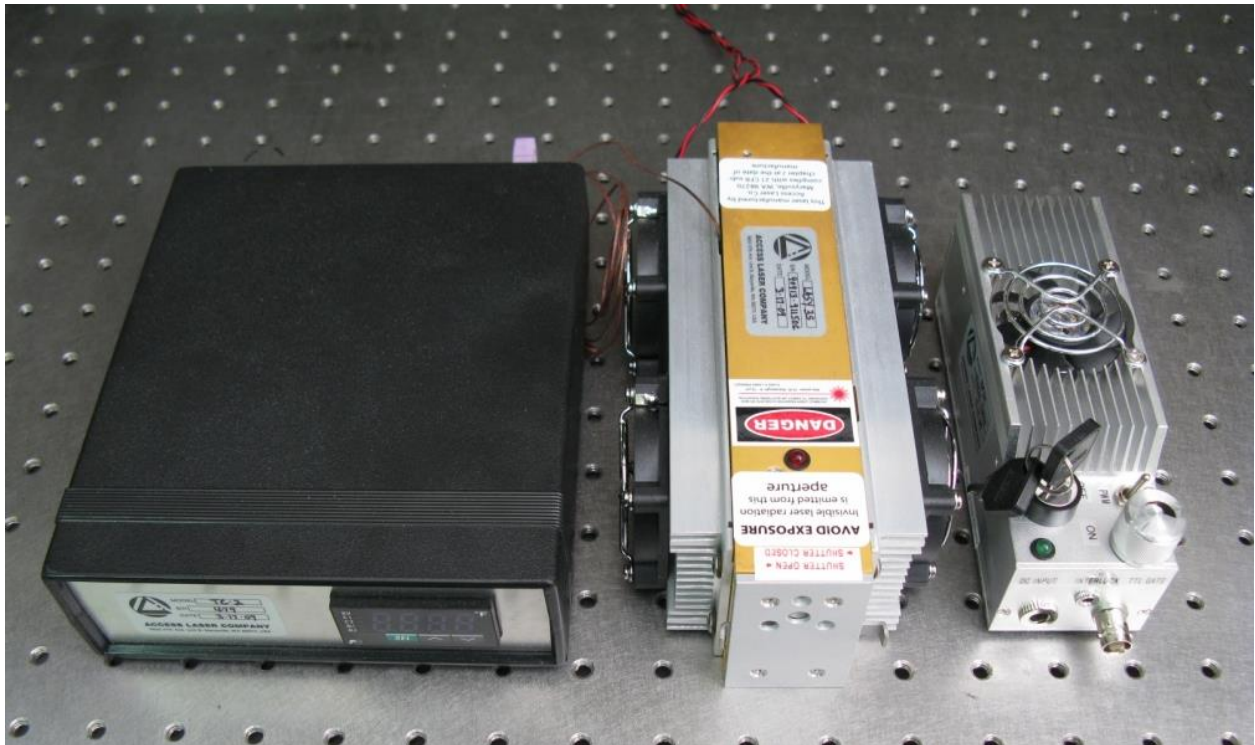

**ACCESS LASER**

where innovation never stops

## *L3 Series Operator Manual*



\*L3S System Pictured Above

Access Laser Company  
917 134<sup>th</sup> St SW Ste A1  
Everett, WA 98204  
425.582.8674  
[www.accesslaser.com](http://www.accesslaser.com)



# TABLE OF CONTENTS

<b>Section</b>	<b>Page</b>
Company Statement.....	3
Contact Information.....	4
Warranty.....	5
Laser Shipment Contents.....	6
The L3 Series.....	7
Safety Information.....	8
Safety Symbols and Terms.....	8
FDA and Federal Regulations.....	9
Safety Label Location.....	10
Laser Operation Instructions.....	11
Operating the Laser.....	11
Water Cooling Connection Diagram.....	14
Water Cooling Connection Instructions.....	15
Wiring Diagrams.....	16
L3S Laser System Connection Diagrams.....	17
Laser Specifications.....	19
L3 Specifications.....	19
L3S Specifications.....	20
L3 Fan Cooled Mounting Dimensions.....	21
RF Driver Specifications & Photo.....	22
RF4 Driver Operation.....	23
OEM Units - Operation instructions.....	26
TC2a Temperature Controller (Standard on the L3S).....	27
Line Tracker (Optional).....	30
Appendix C: Warranty Repairs.....	31



## Company Statement

Thank you for purchasing an Access Laser product. We remain dedicated to your needs long after your initial purchase. In order to help us meet your needs, please contact us if you have any questions, comments or concerns about your laser, at [sales@accesslaser.com](mailto:sales@accesslaser.com) or call us at 425-582-8674. Our staff will make every effort to assure that your laser is operating at its peak performance. We look forward to working with you through the life of your project.



## Contact Information

Access Laser Company is a multi-national company headquartered in Everett, Washington.

Mailing Address	Access Laser Company 917 134 <sup>th</sup> St SW Suite A1 Everett, WA 98204
Phone Number	425.582.8674
Fax Number	425.582.8679
Email	<a href="mailto:sales@accesslaser.com">sales@accesslaser.com</a>

Access Laser Company specializes in innovative solutions to meet your application needs. Our Sales Team and Customer Service Team can provide you with the most up-to-date product information. If you need assistance with an order or service, contact Access Laser Company at 425.582.8674, ext.1 or email your questions.

Sales/Technical Questions	<a href="mailto:sales@accesslaser.com">sales@accesslaser.com</a>
---------------------------	--

Service Department	<a href="mailto:service@accesslaser.com">service@accesslaser.com</a>
--------------------	--



## Warranty

All of Access Laser Company's lasers come with a one-year standard warranty, which certifies that your laser is found to be free of any defects in material or workmanship. This warranty applies regardless of your laser application. It does not cover any issues that may arise due to operator negligence, environmental factors, accident, alterations, or improper maintenance.

Access Laser Company requests that you inspect your shipment within 14 days of arrival. If there appears to be any damage or defect you must notify Access Laser Company, in writing, at [service@accesslaser.com](mailto:service@accesslaser.com). If Access Laser Company is not notified within 14 days, we will assume that the shipment arrived in satisfactory condition.

Please complete the information below upon final inspection of your order.

Date Received:

---

Laser Model:

---

Laser Serial Number:

---

RF Driver Serial Number:

---

Received By:

---

Access Laser Company and its Authorized Distributors maintain the sole authority to make any claims or statements regarding warranty on Access Laser Company products. Access Laser Company reserves the right to make changes or improvements to product design without notice, and without expectation of equivalent changes in products previously manufactured or shipped.



## Laser Shipment Contents

The following items are enclosed with a typical laser shipment:

- L3 Series Laser
- DC Power Supply
- RF Supply
- TNC to TNC Coax Cable (1)
- L3 Series Laser Product Manual
- Laser Test Documents
  - Final Test Document
  - Pulse Power Document
  - Power Plot

If you have questions about the contents of your shipment, please contact us.



## The L3 Series

The L3 Series lasers have an operating power of 400mW in Continuous Wave mode. The L3 Series comes in a bench top model and in a handheld model, for increased portability. The L3 is the standard model in the series The L3S provides increased power stability.

Accessories are available in the L3 series. Operation instructions for these accessories are included in the Appendices of the Operator Manual, or in a separate manual, included with your shipment.

Because Access Laser Company provides innovative solutions to meet your needs, many specialty features are possible with the L3 series. Many of these specialty features may alter the appearance of your laser from what is pictured in the Operator Manual, but they do not alter the basic specifications or operation instructions for your laser. If you have any questions about the specifications or operation of your laser, please feel free to contact us at 425-582-8674, ext 1.



# Safety Information

## *Safety Symbols and Terms*

Commonly used safety symbols and terms are used throughout this manual and on our products. Please familiarize yourself with the definitions and use of the terms and symbols.



Indicates a hazardous situation in which, if not avoided, will result in death or serious injury.



Indicates a hazardous situation in which, if not avoided, could result in death or serious injury.



Indicates a hazardous situation in which, if not avoided, could result in minor or moderate injury.

**CAUTION:** Indicates an unsafe practice that can result in property damage.

Note: Additional information provided for optimal product performance.





# Safety Information

## *FDA and Federal Regulations*

Access Laser Company has designed our lasers to comply with CDRH requirements set forth by United States Radiation Control for Health and Safety Act of 1968. Therefore the L20 series lasers meet all standards for laser products under 21CFR 1040.10 and 21CFR 1040.11. These standards have been set forth to protect the end user from harmful radiation. It is the responsibility of the end user to assure compliance with any and all regulations related to final use or when used outside of the United States.



### Never Open the Laser

To prevent direct exposure from the laser beam and injury to the user, do not try to open the laser. Opening the laser may result in burns, eye damage, misalignment of the laser, or other damage to the laser. The end user will never need to open the laser for maintenance or any other reason. All laser parts are serviceable only by authorized Access Laser personnel. Disassembling the laser voids any warranty.



### Eye Protection Required

The L3 series lasers are Class IV lasers. Class IV Lasers have power outputs of greater than 500 mW. This laser can cause mild to severe burns if skin or eyes are exposed to the beam or scattered radiation. Protective eyewear should be worn at all times.

**▲ CAUTION** Use of controls or adjustments or performance of procedures other than those specified herein may result in hazardous exposure.

**▲ CAUTION** Use Appropriate Beam Blocks

The L3 series lasers produce laser radiation around 10.6 $\mu$ m. This wavelength is invisible and requires special equipment to detect or view. Some materials may cause the laser beam to reflect and scatter, causing injury or damage. Take precautions to block the beam from unintentional reflection. Avoid using materials such as copper, aluminum, or gold as beam blocks which are highly reflective and may cause the beam to scatter. Organic materials may be flammable when exposed to the laser beam. Never use organic materials such as plastic or wood as a beam block. Use a beam block designed for the wavelength and power of your laser, or use a laser power meter.

**CAUTION** Water Cooled Lasers

For water cooled lasers, do not leave the chiller running while the laser is powered off. This may cause condensation in the electrical circuits and optical components, which will lead to damage.



# Safety Information

## Safety Label Location



\*L3S System Pictured Above

**AVOID EXPOSURE**  
Invisible laser radiation  
is emitted from this  
aperture

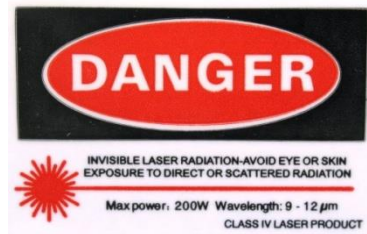

Non-OEM\*

This laser  
manufactured by  
Access Laser Co.  
Everett, WA 98204  
complies with 21 CFR  
subchapter J at the  
date of manufacture.

OEM\*

This laser  
manufactured by  
Access Laser Co.  
Everett, WA 98204  
does not comply with  
21 CFR sub-chapter J  
at the  
date of manufacture.

# Laser Operation Instructions

## Operating the Laser

**NOTE:** If using the LC3 controller, follow the instructions under “Appendix B”.

1. Close the laser shutter (if present).
2. Direct the laser toward an appropriate target, such as a power meter or a beam-blocking device. (See Safety Information on page 9 regarding appropriate beam blocking devices.)
3. Secure the laser to a bench top.

### **⚠ CAUTION**

Do not torque, twist or bend the laser body during the mounting process. Applying uneven pressure to the laser body may distort the laser body, causing poor performance and possible damage.

4. Connect the Cooling System
  - a. Air Cooled Lasers (where cooling is provided by the end user)
    - i. If no cooling is built in to your laser, you are responsible for providing sufficient cooling to maintain the laser specifications
    - ii. Connect your air cooling system to the laser.
  - b. Built-in Fan Cooled Lasers
    - i. Connect the 12V DC supply to the fan power connector.
  - c. Built-in Water Cooled Lasers
    - ii. Connect the tubing to the PISCO fitting as described in the Water Cooling Connection Instructions on page 15.
    - iii. Connect the tubing to the laser and the chiller, as shown in the Water Cooling Connection Diagrams on page 13. Be sure that the tubing input and output are the same on both sides of the laser.
5. If operating an L3S, connect the TC2a. (See Connection Diagrams on page 16 and Appendix B for details.)
  - a. Connect the fan power cable from the laser to the TC2a.
  - b. Connect the thermal couple cable from the laser to the TC2a.



# Laser Operation Instructions

## Operating the Laser

6. Connect the RF cable to the BNC connector on the laser.
7. Connect the RF cable to the TNC connector on the RF Driver.
8. Connect your 5V TTL source to the RF Driver via the TTL gate (BNC connector).
9. Set the TTL input to 0V (0V = OFF; 5V = ON).
10. Connect the RF Driver to the DC power supply.

**NOTE:** Red wire is positive. Black wire is negative.

**NOTE:** The RF driver can be modulated at frequencies from 0 kHz to 100 kHz. Optimal laser performance can be expected at a frequency range of 1-15 kHz.

11. Install the gate enabling D-sub 15 dongle onto the D-sub 15 connector on the RF driver.
12. Verify the beam path is pointed at an appropriate beam blocking device.



### Eye Protection Required

This laser can cause mild to severe burns if skin or eyes are exposed to the beam or scattered radiation. Protective eyewear should be worn at all times.

13. Remove the protective tab from the aperture.
14. Open the laser shutter (if present).



Operate the shutter using the lever closest to your body. Never pass your hand in front of the laser beam to open or close the shutter.

15. Plug in (or apply) the DC power supply to the RF Driver.

**NOTE:** The RF Driver is enabled after a 5 second safety delay, as indicated by the LED on the D-sub 15 dongle. The LED is red during the safety delay and turns amber when the RF Driver is enabled.



The red LED on the laser indicates the laser is powered. When the laser is powered it is able to lase upon application of a control signal.

16. To activate the laser beam, apply 5V through the TTL gate (0V = OFF, 5V = ON).



# Laser Operation Instructions

## Water Cooling Connection Diagram

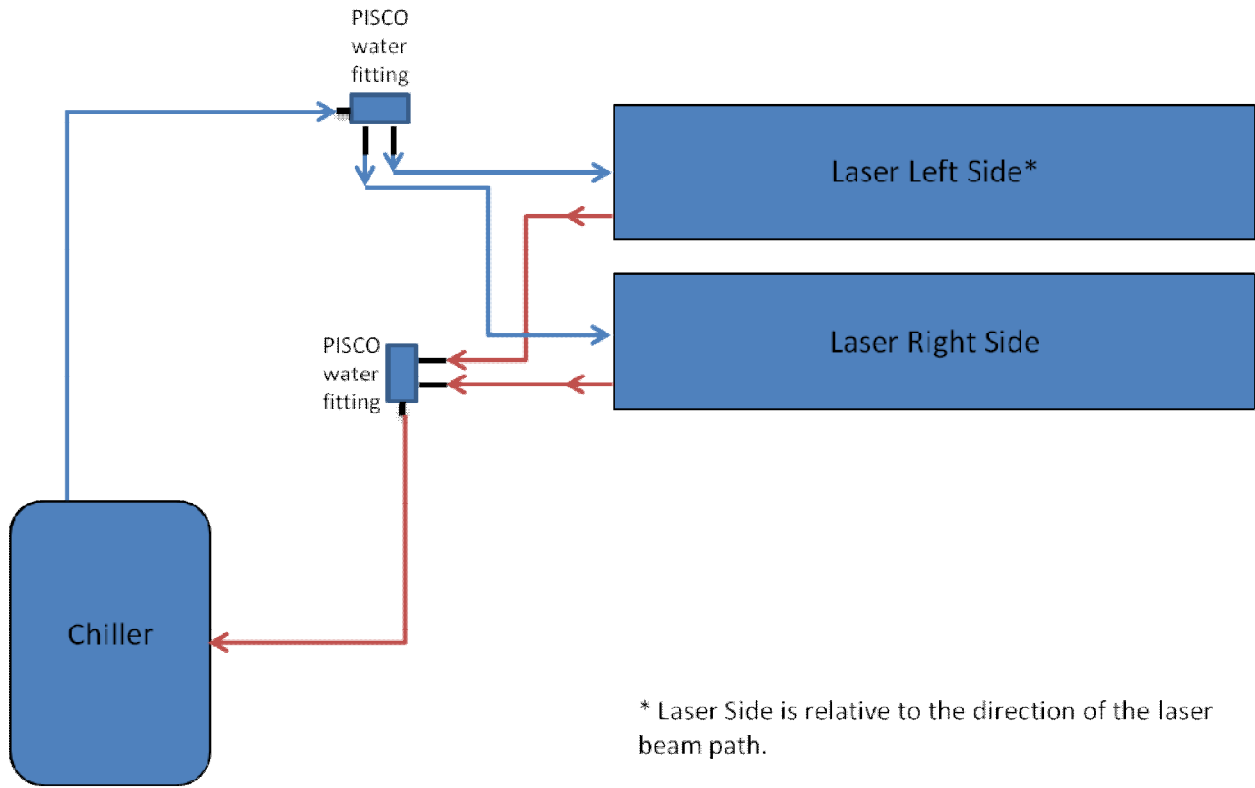

\* Laser Side is relative to the direction of the laser beam path.



# Laser Operation Instructions

## *Water Cooling Connection Instructions*

If your laser is water-cooled, your laser comes with a kit containing the parts required to connect your laser to your chiller (chiller not provided). If assistance is required, please contact Access Laser.

For optimal performance with your water cooling system, keep the laser balanced, cool the left and right sides of the laser equally, and keep the laser stable.

The quick connect tubing fittings are made by PISCO ([www.pisco.com](http://www.pisco.com)). These fittings are easy to use.

### **To Install**

1. The end of the tubing must be cut off clean and flat.
2. The outer surface of the tubing must be free of defects for the first ½+(13mm)
3. The tubing must be round (not distorted).
4. The tubing must be the correct diameter for the fitting.
5. Insert the tubing into the fitting and push it as far as possible. It should go in approximately 0.7+(18mm)
6. Pull gently on the tubing to verify that the small Stainless Steel teeth in the fitting are grabbing the tubing securely.
7. The fitting is ready to be used.

### **To Remove**

1. Push the tubing gently into the fitting.
2. Push the ring into the fitting. This will release the small Stainless Steel teeth from the tubing.
3. While holding the ring close to the fitting, gently pull the tubing out of the fitting.
4. The fitting can be removed and replaced on the tubing multiple times, until the end of the tubing becomes scratched. If the end of the tubing is scratched, it should be cut back to expose smooth surface.

### **To Operate**

1. Always turn on/off the water chiller and the laser power at the same time.



# Laser Operation Instructions

## Wiring Diagrams

### L3 Wiring Diagram

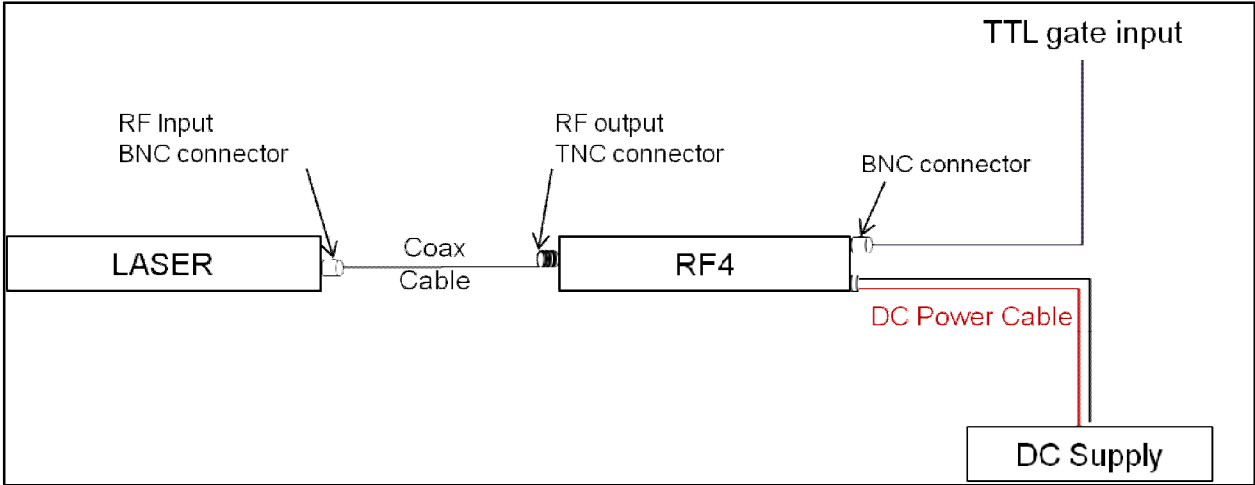

### L3S Wiring Diagram

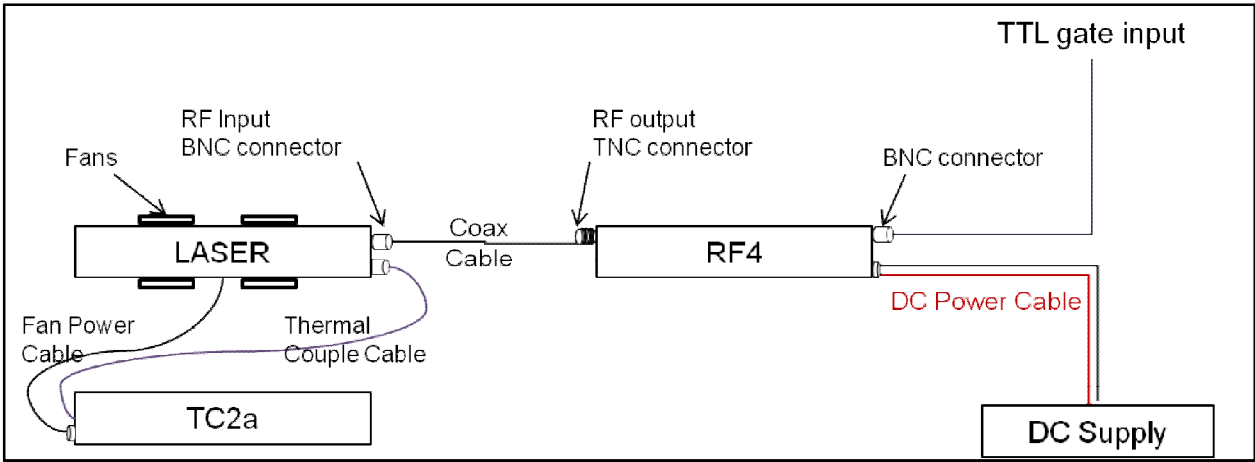



# Laser Operation Instructions

## L3S Laser System Connection Diagrams

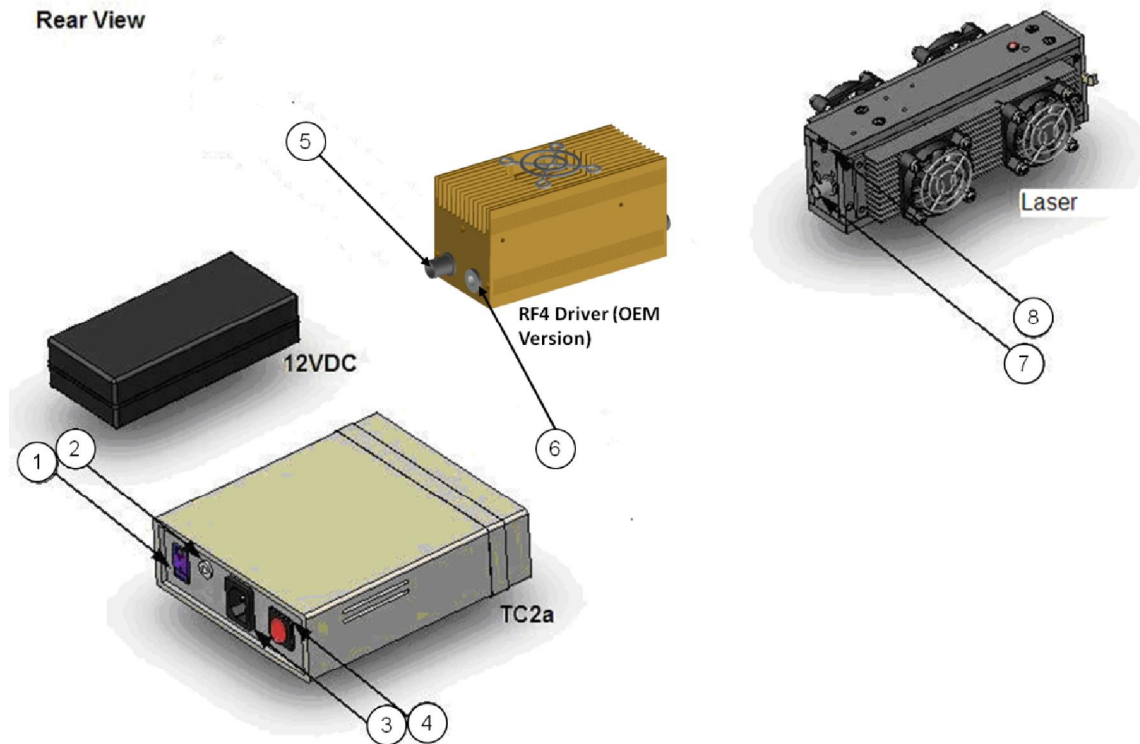

1. Type E Thermocouple Input
2. Controlled fan power out
3. AC power in (110-240V) for TC2
4. TC2 power switch
5. RF driver control signal input, BNC
6. DC power input for RF driver, 12V
7. RF input to laser, TNC
8. Interlock to laser, Mini-USB

Note: Heat sinks, fans, and the TC2a temperature controller are standard on the L3S. They are not included with the standard L3.

# Laser Operation Instructions

## L3S Laser System Connection Diagrams

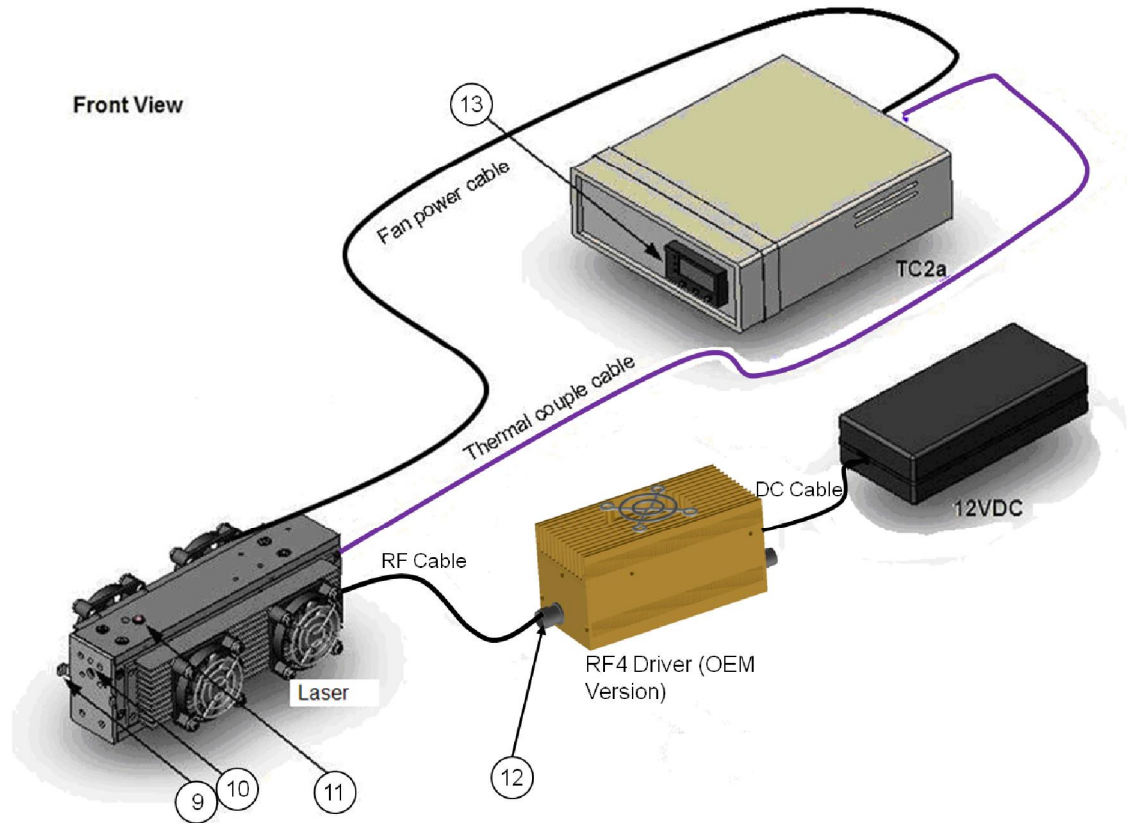

- 9. Manual Shutter
- 10. Laser Beam Exit
- 11. Laser Power-on indicating LED
- 12. RF Output
- 13. Temperature Display



# Laser Specifications

## *L3 Specifications*

<b>Model</b>	<b>L3</b>
Wavelength ( $\mu\text{m}$ )	10.3 - 10.8
CW Power (W)	400 mW
Peak Power (W)	400 mW
Power Stability	$\pm 20\%$
Mode Quality ( $M^2$ )	$< 1.1$
Beam Waist Diameter	2.4 mm
Full Div. Angle	5.5 mrad
Supply Voltage (DC)	12V 20W
Cooling Requirement	Air Cooled
Working Temperature	5-40° C
Dimensions (LxWxH, inch)	7.5x2x2.5

### Options Available

- Fan cooling (Model L3S)
- Stabilization to  $\pm 2\%$  (Model L3S)
- Real time power sampling



# Laser Specifications

## L3S Specifications

Model	L3S
Wavelength ( $\mu\text{m}$ )	10.3 - 10.8
No. of Lines	12
CW Power (W)	400 mW
Peak Power (W)	400 mW
Power Stability	$\pm 2\%$
Mode Quality ( $M^2$ )	$< 1.1$
Beam Waist Diameter	2.4 mm
Full Div. Angle	5.5 mrad
Supply Voltage (DC)	12V 20W
Cooling Requirement	Fan Cooled Closed Loop
Working Temperature	5-40° C
Dimensions (LxWxH, inch)	7.5x4x2.5

### Options Available

- Water cooling
- Real time power monitoring
- Stabilization to  $\pm 1\%$  with Line Tracker



# Laser Specifications

## L3 Fan Cooled Mounting Dimensions

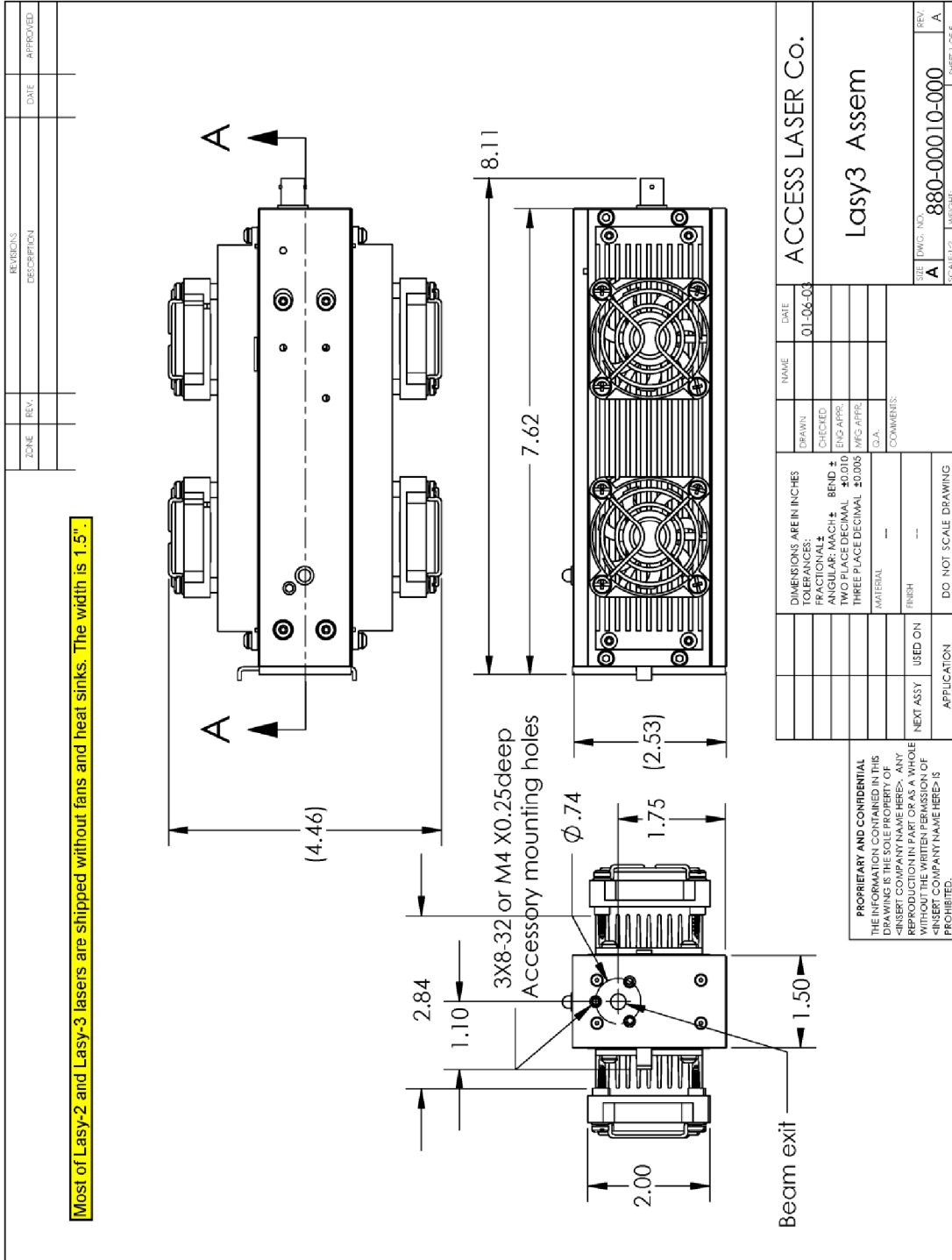

# Laser Specifications

## RF Driver Specifications & Photo

Model:	RF4
Supply Voltage:	12+/-0.4VDC
Output Power:	20W
Frequency:	27.12 MHz
Internal PWM:	16 kHz
Operating temperature:	0 to 60C
Maximum input current:	4A (typical 2.7A)
Typical power dissipation:	9.3W



Figure 1. RF4 Front View (Non-OEM, safety version)



Figure 2. (Rear View)



# Laser Specifications

## *RF4 Driver Operation*

### **Non-OEM Units Description**

There are 10 components to the RF4, pictured above.

1. Key Switch. Enables/Disables RF driver.
2. PWM Control Knob. RF pulse width modulation (PWM) adjustment from 0 (min) to 100% (max) duty cycle. (100% = CW mode).
3. Status LED:
  - Solid red . input DC voltage is applied;
  - Flashing red/green . five second delay after key is turned to ON position (color depends on RF switch on/off status);
  - Solid green . power is enabled and unit is in standby mode;
  - Flashing orange . fault has been detected.
4. PWM Indicator LED. Solid green = RF power is ON (unless PWM knob is at minimum position).
5. Gate activity Indicator. Solid red = gate is externally driven low (0-5V TTL).
6. RF Power Toggle. Toggles RF output on/off. (RF power follows PWM knob).
7. 12V DC input. DC supply jack (center positive).
8. Interlock Input (when using interlock plug)
  - Closed loop = on. This is the default;
  - Open loop = system fault - triggers system shut down. To reset, cycle the Key Switch.
9. Gate input. Defaults active high; gate off RF driver with TTL low input. (400kHz max).
10. RF output. Output connector of RF driver.



# Laser Specifications

## *RF4 Driver Operation*

### **Non-OEM Units - Operation Instructions**

1. Connect RF Driver to the laser as shown in connection diagrams.
2. Plug 12VDC supply into AC power line to apply 12VDC to RF driver.
3. To operate laser in CW① mode, adjust PWM knob to the maximum.
4. To operate laser in PWM① mode, adjust PWM knob to proper position to choose desired duty cycle.
5. Turn Key Switch to ON position. Status LED will flash red for 5seconds.
6. Push RF Power Toggle to turn on RF driver. Both status LED and PWM indicator LED will turn to green. This indicates RF driver is ON.
7. RF Driver runs without gate signal applied.
8. If the external gate signal is desired, the signal needs to meet the requirements of 0 . 400 KHz and 5V maximum.
9. If a customer DC power supply is desired, the required DC voltage range is 12.0 +/- 0.4V, and 5A minimum.

Note: ① CW is continuous wave at 27.12MHz. PWM is pulse width modulated at 16 KHz.





# Laser Information

## *RF4 Driver Operation*

### **OEM Units Description**

1. 12V DC input:  
DC supply jack (center positive).
2. Interlock input (when using interlock plug)  
Closed loop = on;  
Open loop = system fault - triggers system shut down. To reset, cycle the Key Switch.
3. Gate input  
Defaults active high; gate off RF driver with TTL low input. (400kHz max).
4. RF output  
Output connector of RF driver.



# Laser Information

## *RF4 Driver Operation*

### **OEM Units - Operation instructions**

1. Connect RF Driver to the laser as shown in connection diagrams.
2. Plug 12VDC supply into AC power line to apply 12VDC to RF driver.
3. RF driver runs without gate signal applied.
4. If the external gate signal is desired, the signal needs to meet the requirements of 0 . 400 KHz and 5V maximum.
5. If a customer DC power supply is desired, the required DC voltage range is 12.0 +/- 0.4V, and 5A minimum.



## Appendix B: Optional Accessories

### *TC2a Temperature Controller (Standard on the L3S)*

#### TC2a Specifications

Supply Voltage: 110V AC to 240V AC

Features: Improved stability in laser power and wavelength by providing closed loop temperature control of the laser. A laser can expand and contract with changing temperatures, reducing the laser's stability in power and wavelength. A laser becomes more stable when the laser resonator is kept at a constant temperature.



The TC2a temperature controller is integral in the . S version lasers, providing a stability of  $\pm 2\%$ .

Closed loop cooling provides a constant feedback loop to assure consistent temperature of the laser. The feedback loop monitors the laser temperature and cycles the cooling fans to achieve the desired constant temperature. The TC2a works together with our advanced resonator structure and temperature sensor to achieve high stability, both in power and wavelength. This minimizes thermal expansion and contraction of the optical resonator due to ambient temperature fluctuations.

A temperature sensor is built into the laser and measures the temperature of the laser resonator, feeding the information back to the TC2a. The TC2a then controls the temperature by turning the cooling fans on and off to stabilize the length of the laser, thereby achieving stability of both laser power and laser wavelength. Properly adjusting the temperature settings allows for wavelength tuning, within a specified range.

More information about the TC2a controls can be found in the Micro-controller X Instruction Manual, provided in your laser shipment.



## Appendix B: Optional Accessories

### *TC2a Temperature Controller (Standard on the L4S)*

#### **Operation Instructions for TC2a when used with RF4 Driver**

To find the temperature range for the TC2a:

- Run the laser at full power (no modulation) with the fans constantly on. The laser temperature should rise approximately 6° F above room temperature.
- Run the laser at full power with the fans off. The laser temperature should rise approximately 25° F above room temperature.
- This gives the maximum range above ambient temperature that the controller should be set to (25°F. 6°F=19°F).
  - For example, with an ambient room temperature of 68°F, the temperature settings can be between 74°F (68°+6°) and 87°F (68°+19°).
- Different wavelengths may be tuned in and stabilized by setting the temperature controller within the maximum range. A calibration table specific to your laser was created at the time of your laser's manufacture. Because lab conditions vary, the calibration table provides you with an approximation. A final calibration table should be created in your own lab environment. This calibration table is included as part of the final Test Documents included in your laser's shipment.
- From a cold start, thermal equilibrium and stability are achieved after approximately 30 to 45 minutes.

#### Notes

- The temperature rise will differ at duty cycles of less than 100%. The set point on the TC2a where the laser is most stable at the desired wavelength will therefore be different.
- If the power is not within the desired stability the laser may switch from one wavelength to another. Try adjusting the set point by  $\pm 0.1^\circ \text{ F}$  to  $\pm 0.4^\circ \text{ F}$ . This will re-center the laser resonator for a particular wavelength.
- The controller has an auto-tune feature for its PID control. A cycle time of approximately 7 seconds is expected, with a proportional band set around 1° F.



## Appendix B: Optional Accessories

### *TC2a Temperature Controller (Standard on the L4S)*

#### Temperature Controller Default Settings

P = 1	P-N2 = 8
I = 125	P-SL = 32
D = 28.8	P-SU = 150
CTRL = PID	P-DP = 1
TC = 7	P-N1 = 3

#### **CAUTION**

This controller is intended for Continuous Wave (CW) laser operation. If you modulate the laser to achieve different power levels, the laser resonator will have different thermal characteristics and the TC2a may not perform as designed.

#### **CAUTION**

Air from fans may interfere with laser power monitoring.



# Appendix B: Optional Accessories

## Line Tracker (Optional)

### Closed-loop Spectrum/Power Stabilizer

A line tracker is available as an accessory for any . S or . G model laser. A line tracker maintains a fixed wavelength at a high degree of power and frequency stability in a CO<sub>2</sub> laser. The line tracker consists of a beam sampling assembly, a Piezo actuator and a controller. The Line Tracker can be connected to a computer through an RS-232 interface for information and data logging. Any of the Access Laser . S (stabilized) or . G (grating tuned) lasers can be equipped with Line Tracker to achieve more robust, longer term operation of  $\pm 1\%$  power stability, even in outdoor applications where the ambient environment fluctuates.

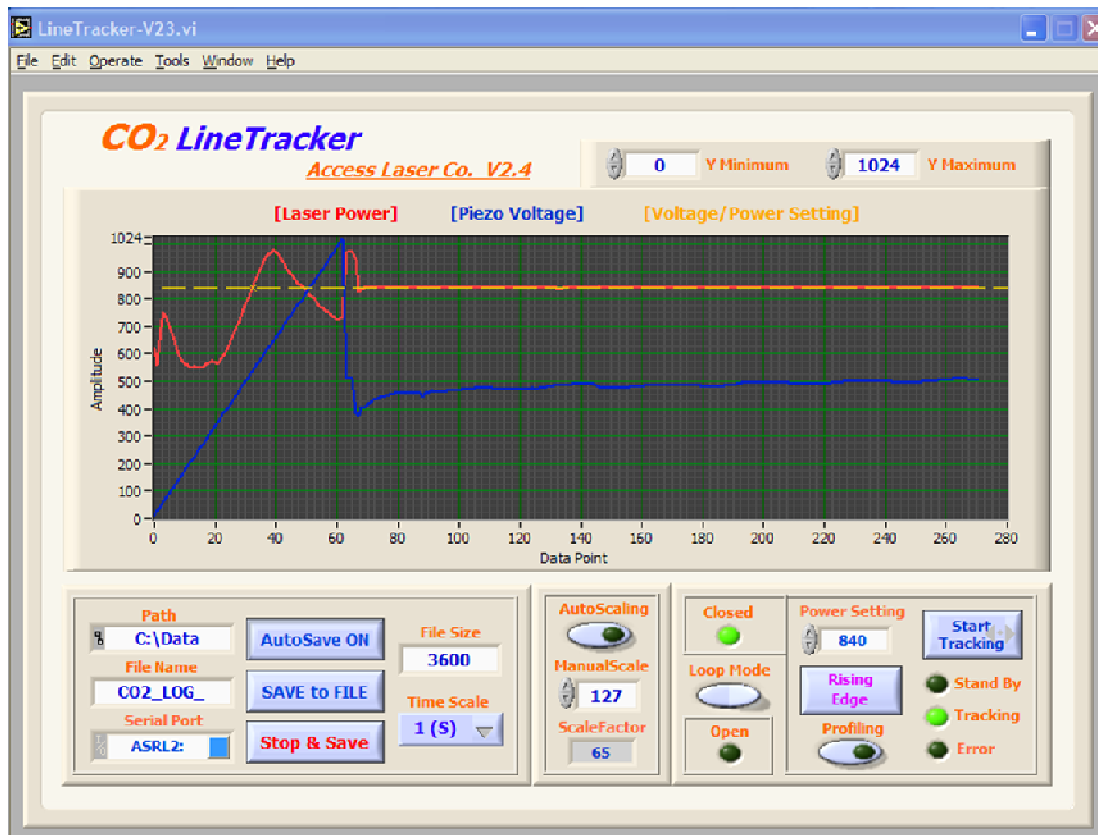

Screen shot of the Line Tracker computer interface. This plot was obtained with an L4S laser.



## Appendix C: Warranty Repairs

If a failure should occur, please contact your Access Laser Company representative, or contact our Headquarters at 1-425-582-8674 or at [service@accesslaser.com](mailto:service@accesslaser.com). A Company representative will determine whether your laser should be returned for repair or maintenance. If the laser needs to be returned, a Return Merchandise Authorization (RMA) will be issued. Any laser returned without an RMA will be at your sole expense.

An ALC representative will make a determination regarding shipping costs. Typically, for failures within the first 45 days, ALC pays all shipping costs to and from ALC. For failures after 45 days, but within the first year, the client shall be responsible for shipping costs to ALC. ALC will pay all shipping costs to return the item(s) to the client. Special considerations may apply. Be sure to verify shipping costs with your ALC representative.

When requesting an RMA please have the following information ready:

- Date of purchase
- Laser model
- Serial number the laser
- Serial number for the RF driver
- Date the issue was first discovered
- Brief description of the issue

Fill out the RMA as completely as possible. Include a copy of the RMA in the laser package. Also fax a copy to us at 1-425-582-8679, Attention: Service. When faxing the RMA please include the tracking number for the return shipment.

For any returns, please ship the item(s) to:

Access Laser Company  
Attn: Service Department  
917 134<sup>th</sup> St SW, Suite A1  
Everett, WA 98204

Include the laser and ALL accessories when returning the laser. This allows ALC to test each component and determine the source of the issue.

